



# HAR-600 AIR REGULATOR AND GAUGE HAR-507 AIR REGULATOR

**IMPORTANT:**

Read and follow all instructions and SAFETY PRECAUTIONS before using this equipment. Retain for future reference.

**WARNING**

Risk of personal injury.  
Risk of property damage.

Except as otherwise specified by the manufacturer, this product is specifically designed for compressed air service and use with any other fluid (liquid or gas) is a misapplication. For example, use with or injection of certain hazardous gases in the system (such as oxygen or liquid petroleum gas) could be harmful to the unit or result in a combustible condition that may cause fire or explosion. Manufacturer's warranties are void in the event of misapplication and manufacturer assumes no responsibility for any resulting loss.

**WARNING**

Risk of injury. Release all air pressure from system before servicing system. Be sure to read and understand all Service Bulletins on the separate components before using the system. Use only specified DeVilbiss parts.

**DESCRIPTION**

This regulator has been designed to receive air at main line pressure and to deliver it at a desired lower regulated pressure.

**Specifications**

Air inlet	3/8" NPT(F)
Air outlets	1/4" NPT(F) (3 Ea.)
Air Capacity	60 CFM
Maximum Temp.	150° F
Max. Inlet Pressure	250 psi
Regulator range	0-125 psi

**INSTALLATION**

1. Maximum inlet pressure and operating temperature ratings are 250 psig and 150° F (intermittent to 180° F).
2. Install as close as possible to where regulated air is needed.
3. Install the unit with the air flowing through the body in the direction indicated by the arrow.
4. Install the same pipe size unit as the pipe line in use. Avoid using fittings, couplings, etc., that restrict the air flow, unless maximum flow is not needed.
5. Regulator may be installed so that adjusting handle is in any position. Attach gauge to one 1/4" female port.
6. Turning the adjusting screw clockwise increases the regulated pressure and turning it counterclockwise reduces the regulated pressure.

**IMPORTANT! DO NOT DESTROY**

It is the Customer's responsibility to have all operators and service personnel read and understand this manual. Contact your local DeVilbiss representative for additional copies of this manual.

---

**READ ALL INSTRUCTIONS BEFORE OPERATING THIS DEVILBISS PRODUCT.**

**REGULATOR MAINTENANCE**

1. Occasionally remove bottom plug (7) and clean valve seat (11) and body. Clean parts with denatured alcohol, wipe off seat and blow out body with compressed air.
2. To disassemble regulator, remove screws, bonnet, spring and spring button. Diaphragm assembly can now be removed.
3. Check all O-rings for signs of damage. Replace if necessary.
4. Reassembly parts. Insert stem of valve through hole in regulator body. Install spring and o-rings. Screw bottom plug into body.

**Note**

Erratic operation or loss of regulation is usually due to dirt in the valve area and cleaning is necessary. If cleaning does not correct the problem, replace the items included in Repair Kit KK-4977. If unit leaks air at [A], install Repair Kit KK-4977.

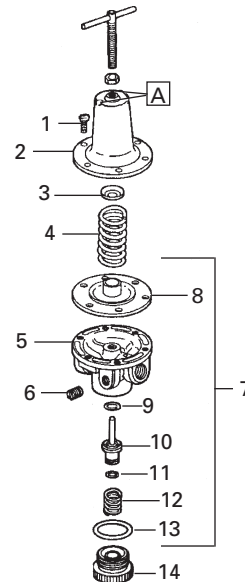

**PARTS LIST - Model HAR-507 Regulator Assembly**

Ref No.	Replace. Part No.	Description	Ind. Parts Req.
1	—	#10-32x9/16 Fillister Hd. Screw	6
2	HAR-14	Cover	1
3	—	Spring Button	1
4	—	Diaphragm Spring	1
5	—	Body	1
6	—	Pipe Plug 1/4" NPT(M)	1
7	KK-4977	Repair Kit (includes # 8 thru 13)	1
8	—	Diaphragm Assy.	1
9	—	O-Ring	1
10	—	Valve	1
11	—	O-Ring	1
12	—	Spring	1
13	—	O-Ring	1
14	—	Bottom Plug	1

Model HAR-600 Regulator and Gauge Assembly

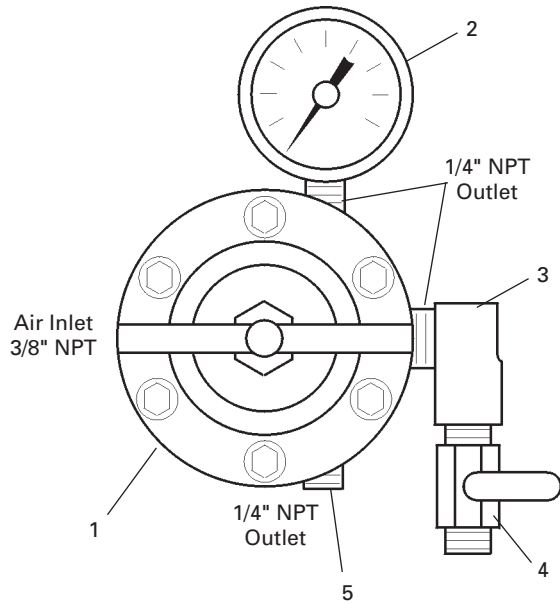

PARTS LIST - HAR-600 Regulator and Gauge

Ref No.	Replacement Part No.	Description	Ind. Parts Req.
1	HAR-507	Regulator	1
2	GA-288	Gauge	1
3	—	1/4" NPT Street Elbow	1
4	VA-542	Ball Valve	1
5	—	1.4" NPT Plug	1

INSTALLATION

Assemble gauge (2), elbow (3), ball valve (4) and plug (5) to regulator as shown. Use quality pipe sealant or PTFE tape (not supplied) when installing above components and when installing regulator to air line piping.



**PROP 65 WARNING**  
 WARNING: This product contains chemicals known to the State of California to cause cancer and birth defects or other reproductive harm.

---

**NOTES**

---

## WARRANTY POLICY

This product is covered by Carlisle Fluid Technologies' materials and workmanship limited warranty. The use of any parts or accessories, from a source other than Carlisle Fluid Technologies, will void all warranties. Failure to reasonably follow any maintenance guidance provided may invalidate any warranty.

For specific warranty information please contact Carlisle Fluid Technologies.

Carlisle Fluid Technologies is a global leader in innovative finishing technologies. Carlisle Fluid Technologies reserves the right to modify equipment specifications without prior notice.

DeVilbiss®, Ransburg®, ms®, BGK®, and Binks®  
are registered trademarks of Carlisle Fluid Technologies, Inc.

©2018 Carlisle Fluid Technologies, Inc.  
All rights reserved.

---

For technical assistance or to locate an authorized distributor,  
contact one of our international sales and customer support locations.

<b>Region</b>	<b>Industrial / Automotive</b>	<b>Automotive Refinishing</b>
Americas	Tel: 1-800-992-4657 Fax: 1-888-246-5732	Tel: 1-800-445-3988 Fax: 1-800-445-6643
Europe, Africa, Middle East, India	Tel: +44 (0)1202 571 111 Fax: +44 (0)1202 573 488	
China	Tel: +8621-3373 0108 Fax: +8621-3373 0308	
Japan	Tel: +81 45 785 6421 Fax: +81 45 785 6517	
Australia	Tel: +61 (0) 2 8525 7555 Fax: +61 (0) 2 8525 7575	

For the latest information about our products, visit [www.carlisleleft.com](http://www.carlisleleft.com)